

1. Handling and Installation



CAUTIONS (For Safe Operation)

- Always wear (proper) clothing and protective equipment (safety goggles and (proper) shoes) appropriate to the job.
- Pay attention to safety of work crew and surrounding workers.
- Follow the related labor safety regulations.
- Before starting the work, make sure to turn power off, and avoid accidental power-on. Also, be careful that clothing or part of body is not caught by a chain, sprocket, or peripheral equipment during work.
- Clean work area, and work in safe environment.
- Do not stand or walk under lifting equipment.
- Before transferring a chain, be sure to secure it firmly.

Adjusting Chain Length (Number of Links)

1. To shorten a chain to an appropriate length, use a proper jig, and employ a method appropriate to the structure of a chain. It is recommended to use an exclusive jig.
2. To shorten a riveted chain, grind away riveted ends of a pair of rivets in the same link (on the same side).
3. Place a punch at ground end of a rivet, and strike a punch with a hammer. Be careful to hit two pins alternately. If pin is withdrawn without grinding off riveted end, a chain will be damaged. Grind away riveted ends.
4. After withdrawing pins, check to see if bushings are set correctly. If bushings are protruded, smooth power transmission cannot be achieved or strength of a chain is reduced.
5. Do not reuse the removed parts.

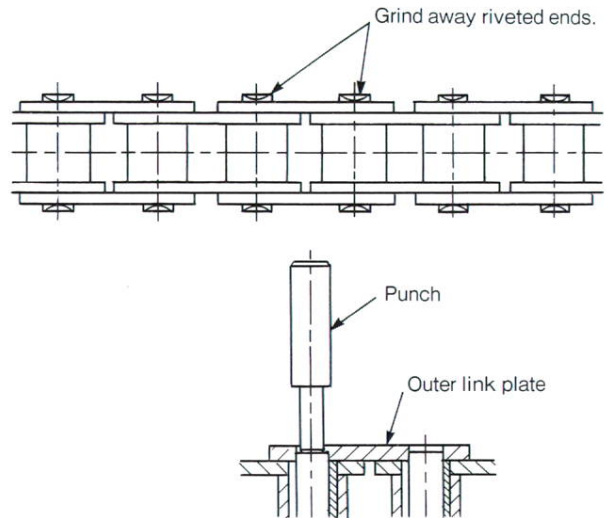

Connection (Installation to Equipment)

1. Confirm that sprocket shafts are parallel and level, and misalignment of sprockets is within tolerance.
2. Insert a connecting link between both ends (inner links) of a chain. In this case, this connection can be easily made when a chain is engaged with sprockets.
3. When inserting a connecting link, it is important that split pin hole or clip groove is exposed over a connecting link.
4. Install a split pin and clip.
 - Open ends of split pin at 60° as shown.
 - Install a clip in direction opposite to chain advancing.

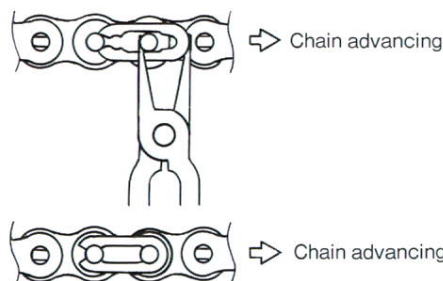
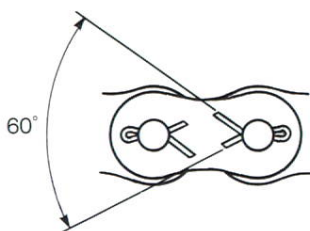

- Use genuine split pins or a clip.
- Note that connecting link will be disengaged in case of improper installation. Causing injury to people or equipment damage.

Proper Slack

Proper slack "S" is determined by the following equation.

$$S = 0.02L$$

where, L is span

Adjust shaft-to-shaft distance to set proper slack "S".

In the following cases, determine slack "S" by the equation of $S \leq 0.01L$.

- Vertical arrangement
- Upper side of chain is slackened.
- Shaft-to-shaft distance exceeds 50 times pitch.
- Vibration or impact is present.
- Chain starts and stops frequently.
- Forward/reverse movements are repeated frequently.
- Speed change ratio exceeds 7:1.

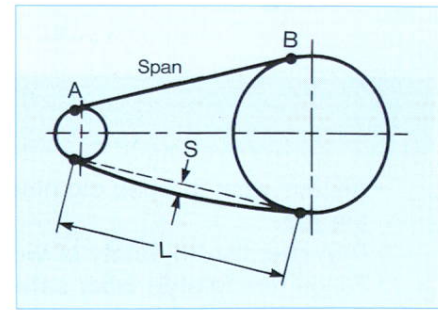

Proper shaft-to-shaft distance is 30 to 50 times pitch.



CAUTIONS (Remanufacturing and additional manufacturing are prohibited.)

- ⊘ Remanufacturing and additional manufacturing of chain and related parts are prohibited. Otherwise, this will lead to chain failure. If remanufacturing or additional manufacturing is necessary, contact us.
 - Electric plating will lead to brittle breakage.
 - Welding of heat-treated chain will cause cracks or sacrifice strength.
 - Annealing of heat-treated chain will reduce strength of part.
 - Enlargement of connecting link hole and reduction in connecting pin diameter will reduce strength.

2.Operation

Check Items Before Operation

- Before operation, check if the following items are correctly set and safety cover is installed.
- If abnormal noise is caused during operation, immediately stop operation, and find cause of trouble and remedy.

| Check items | Description |
|----------------------|--|
| Engagement | Check if sprocket is engaged correctly and slack is proper. |
| Link connection | Check if links are connected correctly and parts are firmly seated. |
| Interference | Check if there is any part or equipment that interferes with chain or any part that will be shattered. |
| Lubricant | Check if lubrication is proper. |
| Safety cover | Check if proper safety cover is installed. |
| Peripheral equipment | Check if peripheral equipment is installed. |

Lubrication

Roller chain lubricated with oil or grease will splash at the start of operation. To avoid splashing of lubricant on clothing and skin, stand an appropriate distance away upon start up.

- Insufficient lubrication of chain will promote wear of pins and bushings due to dry friction. This will result in elongation of chain and poor performance of chain. To ensure service life of chain, choose the right lubricant and lubrication method to meet operating requirements. For correct chain selection when no lubrication is allowed, contact us or our dealer.

Lubricating Points:

- ① Clearances between inner and outer links (to avoid elongation of chain)
- ② Clearances between rollers and inner links (to reduce wear of bushings and rollers, to avoid their breakage, and to suppress noise)

